



## WirelessSentinel (WS-1000-WF Series)

WiFi Universal Serial Converter and WiFi Solar  
powered Micro "RTU"

### Data Sheet

S-WFI-1401-07-001 Rev.3

### Features

- Comply with RS-232, RS-485 and IEEE 802.11b/g/n (WiFi) standards.
- Converts RS-232 or RS-485 (two wires) to WiFi.
- Supports any asynchronous byte oriented serial protocol (i.e. Modbus RTU, DF1, etc.) in transparent mode.
- RS-485 up to 4,000 ft. (1200m) in multi-drop configuration.
- Serial data rates from 2400 bps to 250 Kbps.
- WiFi data rates up to 72 Mbps.
- Allows remote access to RS-485 networks, and point-to-point RS-232 connections thru WiFi.
- Supports Ad Hoc WiFi wireless point-to-point connections, as well as, infrastructure point to multipoint networks.
- Different I/O options (depending on the model). Two 0 to 20 mA (10 bits resolution) analog inputs, 1 discrete input (up to 30 Vdc), one discrete output (up to 30 Vdc @ 250 mA), one 0-20 mA analog output (8 bits resolution).
- Built-in (dual level) lead acid 12Vdc or 24 Vdc battery charger for up to 1A continuous loading current.
- Solar panel input for battery charging (up to 30W solar panel).
- WiFi Radio with built-in or external antenna (SMA male connector).
- DIN rail mounted.
- "Plug-in" terminal blocks for fast installation and removal.
- Sleep and deep sleep modes allows very low power consumption for battery operation for long time periods (sleep times are configurable).

- Protection against reverse power supply polarity, surges and transient protection for all inputs and outputs.
- Leds to indicate power, WiFi link status, and data transmission/reception.
- Over the air configuration.
- Designed for industrial use.
- Works as wired or Wireless Micro RTU supporting Modbus RTU slave protocol, Modbus TCP and HART.
- Works as Modbus RTU wireless repeater for extended radio links.

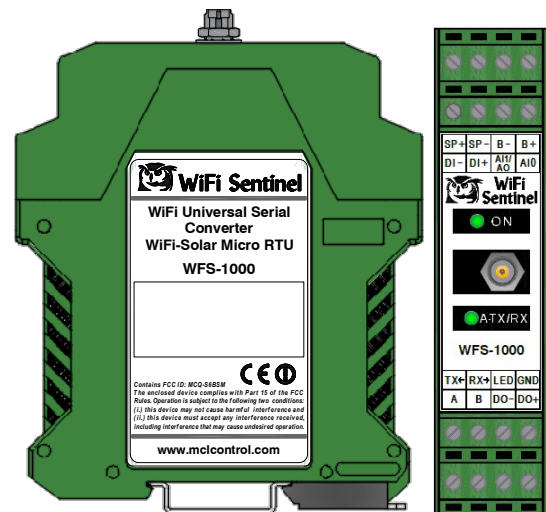

### Typical applications

As Wired (RS-232/RS-485) to Wireless (WiFi) converter for point-to-point connections.

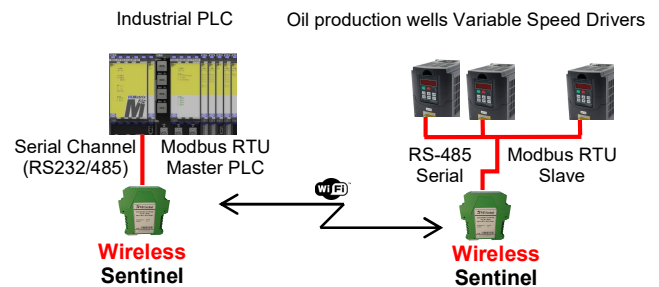



The previous figure shows an application where a PLC monitors supervise and controls remote Variable Speed Drivers (VSDs) in Oil producing Wells. The Master PLC (i.e. Modbus RTU) is connected wirelessly to the VSDs (i.e. Modbus Slaves) by means of a couple of **WirelessSentinels** working in serial to WiFi converting mode (any serial asynchronous 8 bits protocol is supported). This application allows significant reduction in construction and installation cost, and also the likelihood of problems inherent to wired networks like electromagnetic interference from VSD power cables to the RS-485 wiring in long distances, ground loops, power surges, atmospheric discharges and many others.

The **WirelessSentinels** can be connected in AdHoc mode (no need of WiFi routers) or in infrastructure mode (any industrial WiFi router / Access Point is supported).

As a Solar Powered Remote Terminal Unit (RTU).

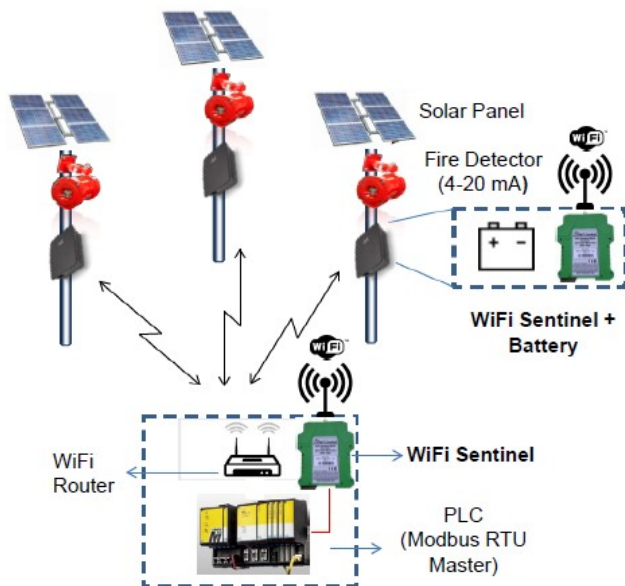

In this application fire and/or gas (F&G) detectors are deployed in an industrial plant. Up to two detectors can be wired (4-20 mA) to one **WirelessSentinel** which also loads the battery from a solar panel. The **WirelessSentinel** works in RTU mode as a Modbus RTU Slave reporting the F&G detectors status to a

master PLC which is connected serially to a **WirelessSentinel** working as a serial to WiFi converter.

Instead of F&G detectors, any process variable transmitter can be connected to each **WirelessSentinel**, also one discrete input signal and one discrete output signal can be connected to each **WirelessSentinel**.

## Specifications

- Power Voltage: 8-30 Vdc. Reverse polarity protected.
- Power consumption: 700 mW average transmitting at maximum power, 200 mW in sleep mode reporting each 5 seconds.
- Serial channels:
  - Serial data rates RS-232/RS-485:
    - 2.400, 4.800, 9.600, 19.200, 38.400, 57.600, 115.200, 230.400 bps in serial to wireless converting mode.
    - 4.800, 9.600, 19.200, 38.400 bps in Modbus RTU slave mode.
  - Serial transmission mode: Asynchronous "Half or Full Duplex" in RS-232, "Half Duplex" in RS-485.
  - Serial data format: 8 Bits, even parity, odd parity or no parity, one start bit, 1 or 2 stop bits.
  - Serial data interfaces:
    - RS485 two wires (A and B), "Half Duplex". 120 Ω end of line termination resistor can be enabled via switch. +80V over-voltage protection between terminals A/B to ground. 40V (clamping) over-voltage protection between ground and shield.
    - RS-232 available signals: TxD, RxD, GND.
- WiFi radio specification: XBee® Wi-Fi IEEE 802.11 bgn compatible radio operating between 2.4 to 2.5 GHz (13 channels available). +28.75 dbm (0.75 Watts) peak power.
- Radio receiver sensitivity: -93 dBm to -71 dBm.
- Battery charger:
  - Solar power input: 8 to 40 Vdc. Protected by resettable fuse against reverse polarity.



- Maximum battery charging current: 900 mA @ 36 V. Internally protected by 1A fast acting fuse.
- Battery type: Sealed lead acid or GEL.
- Floating voltage: 13.5 Vdc for 12 Vdc batteries, 27 Vdc for 24 Vdc batteries (Battery voltage depends on the model).
- Maximum battery voltage: 14.4 Vdc for 12 Vdc y 28 Vdc for 24 Vdc (Battery voltage depends on the model).
- Inputs and Outputs:
  - Discrete Input:
    - Number of inputs: 1
    - Nominal Voltage: 24 Vdc
    - On state voltage: 8 to 30 Vdc
    - Off state voltage: 0 to 1 Vdc
    - On state current: 0.3 mA @ 8Vdc, 1.4 mA @30Vdc
    - Off state current: < 0.25 mA
    - Response time: 20 mS (de-bouncing filter)
    - Reverse polarity protected.
    - Electrical isolation: up to 5000 Vrms (optically coupled).
  - Discrete Output:
    - Number of inputs: 1
    - Maximum voltage: 60 Vdc
    - Maximum current: 300 mA
    - Off state current: < 1 μA
    - Voltage free output.
    - Response time: 3 mS
    - Current protection: 285 mA @ 2s
    - Isolation: 2500 Vrms (Optically coupled)
    - Output impedance: 10 Ω
  - Analog Inputs:
    - Number of inputs: 1 or 2 (depending on the model)
    - Input range and resolution:
      - 0 to 21.5 mA – 21 mA/Count (10 bits)
      - 0 to 1 Vdc – 1.05 mV/Count (10 bits)
    - Input impedance: 250 Ω max
    - Low pass filter: 30 Hz compatible with HART protocol transmitters
    - Scan time: 3 mS minimum
    - Accuracy: +- 0,5% measured value
- Current protection: 100 mA @ 5s (resettable fuse)
- Isolation: None
- Operating temperature: -30°C to 70°C
- Humidity: 95% no condensing
- Dimensions:
  - 12,25 cm (Height) x 2,26 cm (Width) x 9,9 cm (depth)
- Enclosure:
  - Material: Polyamide plastic
  - Flammability according UL 94: V0
- LEDs indicators:
  - Power-on: Green steady.
  - A – Tx/Rx:
    - Amber blinking at 1Hz: indicates the **WirelessSentinel** is associated either with an Access Point (when working in infrastructure mode) or with another **WirelessSentinel** (when working in AdHoc mode).
    - Amber Steady: **WirelessSentinel** is waiting for association.
    - Amber off: **WirelessSentinel** radio is not configured.
    - Green blinking: Data is being received or transmitted over the air.

## Wiring

**WirelessSentinel** is equipped with four terminal blocks each one having four positions or terminals as shown in the next figure.

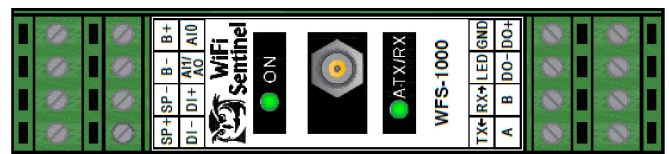



Signal	Description
SP+	Solar Panel input (Positive lead)
SP-	Solar Panel input (Negative lead) (Internally connected to ground)
B-	Battery input or Power Input (Negative lead) (Internally connected to ground)
B+	Battery Input or Power Input (Positive lead)
DI-	Discrete input (Negative Lead) (Internally connected to ground)
DI+	Discrete input (Positive Lead)
AI1/AO	0 – 20 mA analog input current channel 1 or Analog output current (If available) (Note 1)
AI0	0 – 20 mA analog input current channel 0 (Note 1)
Tx←	RS-232 Data to be transmitted (Input)
→RxD	RS-232 received data (Output)
LED	Enable Leds (Note 2)
GND	Ground terminal
A	RS-485 Terminal A (Note 3)
B	RS-485 Terminal B (Note 3)
DO(+)	Discrete Output (Current sink) (Positive Lead)
DO(-)	Discrete Output (Negative Lead)

**Note 1:** The analog inputs common terminal is any terminal connected to ground (SP-, B- or GND).

**Note 2:** To enable the LEDs, a jumper between the LED and the GND terminal must be installed. To save power is recommended to keep the LEDs disabled.

**Note 3:** For proper protection against over-voltage transients and surges for RS-485 channel (A and B terminals), as well as Analog Inputs and Discrete Input, the DIN rail where the **WirelessSentinel** is installed, must be connected to the facility protective ground.

**Note 4:** Refer to the ordering information section to see the signals and functions available for each model.

Typical Wiring diagram is shown in the next figure.

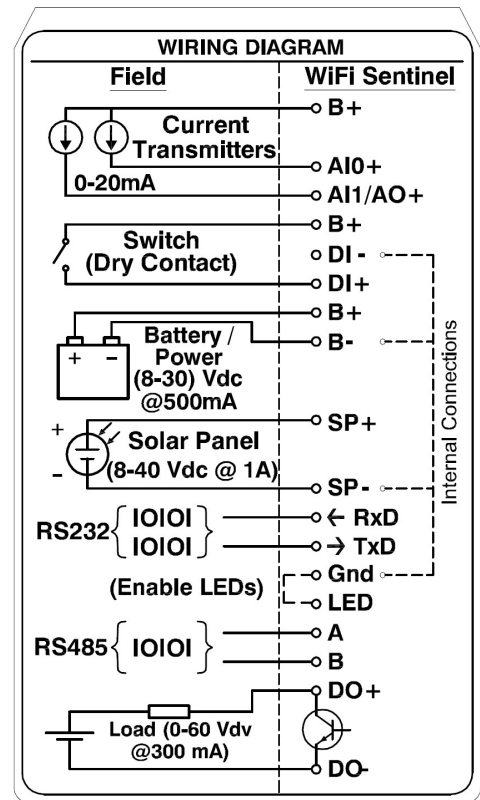

WirelessSentinel Wiring diagram

## Approvals

The **WirelessSentinel** contains an XBee® radio that complies with Part 15 of the FCC rules and regulations. Operation is subject to the following two conditions: (1) this device may not cause harmful interference and (2) this device must accept any interference received, including interference that may cause undesired operation.

### FCC ID: MCQ-XBS6B

**Warning:** To satisfy FCC RF exposure requirements for mobile transmitting devices, a separation distance of 20 cm or more should be maintained between the antenna of this device and persons during device operation. To ensure compliance, operations at closer than this distance are not recommended. The antenna used for this transmitter must not be co-located in conjunction with any other antenna or transmitter.



## Ordering information and support

### Ordering information:

Series: WS-1000-WF

Model	Description
WS-1001-WF	Modbus RTU slave WiFi Micro RTU, Two analog inputs, One Discrete Input, One Discrete Output, WiFi Radio, no battery charger
WS-1002-WF	Modbus RTU slave Micro RTU, two analog inputs, One Discrete Input, One Discrete Output, no WiFi Radio, no battery charger
WS-1003-WF	Serial to WiFi Converter, no I/O, no Battery charger
WS-1010-WF	Modbus TCP Server (slave) WiFi Micro RTU, Two analog inputs, One Discrete Input, One Discrete Output, WiFi Radio, no battery charger
WS-1011-WF	Modbus TCP Server (slave) WiFi Micro RTU, Two analog inputs, One Discrete Input, One Discrete Output, WiFi Radio, no battery charger, serial port to connect the Sentinel Gas Detector (SGD-1000).
WS-1012-WF	Modbus TCP Server (slave) WiFi Micro RTU, Two analog inputs, One Discrete Input, One Discrete Output, WiFi Radio, no battery charger, HART protocol for up to 5 slave devices.

## Support

MCL Control USA, Inc.

E-mail: [jcalderon@mclcontrol.com](mailto:jcalderon@mclcontrol.com)

[www.mclcontrol.com](http://www.mclcontrol.com)